

Forest Composite Decking Laying guide

Important information

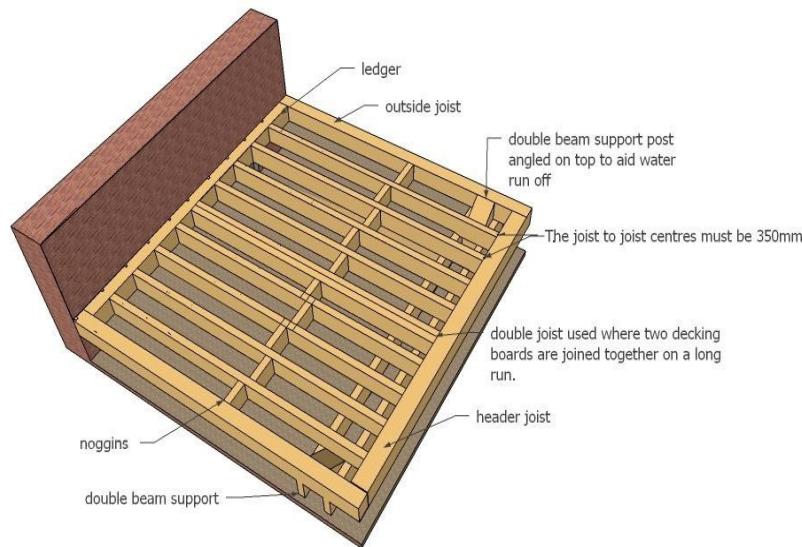

Always make sure the ground that you are building on is a suitably hard and well drained base for your project. When setting out building the deck it is important to know that joist spacing's on the sub-frame must be no more than 400mm centres max and all joints upon the deck surface should be laid on a double joist layout with a gap for drainage. Starter clips are the ideal way to start laying your board where space is limited.

Where the end of two decking boards meet there should be one joist for each end of the board. Do not fasten board ends on one joist as it does not allow for drainage or proper expansion and contraction. Keep a small gap between the joists for each end to allow drainage.

Starter clips



Place the starter clip (TC5) flat side down on the frame and push the hooked end up to wall and screw down using the screw provided.

Repeat this down the length of your board at each 350mm joist location, it is important to place a Starter clip close to the ends of the board about 10mm from the end.

When all the necessary starter clips are in place push the board into Position making sure the hook on the clip goes into the channel profile on the side of the board.



OUT



IN

Joint line

Allowing for the correct spacing of all gaps and joints is very important, like with wood and other building materials all composite decking shrinks and expands with the changes in climate. See temperature change info and charts on pages 7 and 8.

Expansion and contraction needs to be taken into consideration when installing any wood-plastic composite. It's a natural tendency for objects to expand and contract from changes in temperature.

We have taken this into consideration and created a clip system which will ensure your deck experiences zero warping or distortion after installation so that you can enjoy the perfect deck every day.

We generally recommend placing the TC-1 clip at the centre of your layout to allow expansion to take place at either side.

Functions of each clip:

The TC-1 secures the board and controls the direction in which expansion and contraction takes place. The TC-2 locks yet also permits flexibility so that each board can still expand and contract enough so that it doesn't warp, distort, or buckle from these movements.

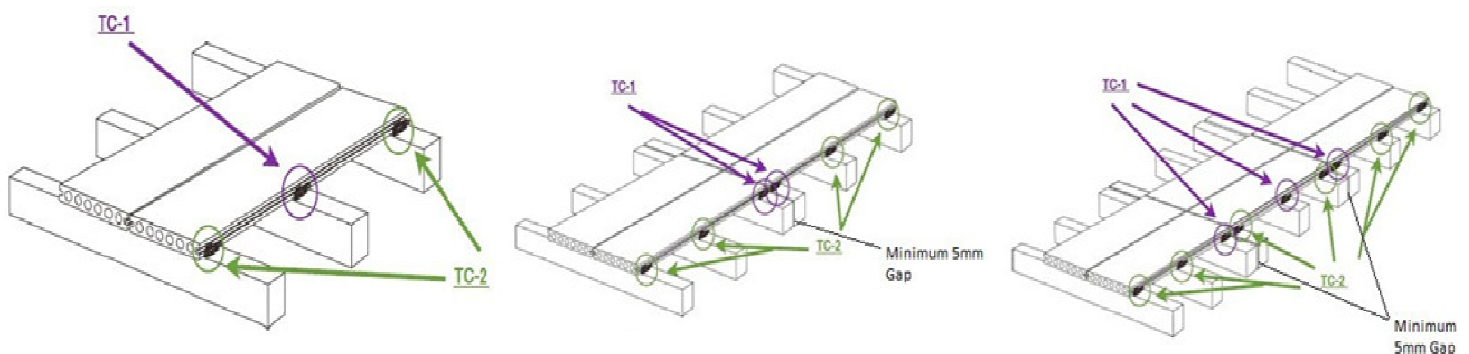

Metal fasteners are also available for use that create a smaller gap between the boards. Many installers prefer these fasteners but they do not allow for control of the expansion and contraction direction therefore are not covered by the warranty.

Edging trim

The L shape edging trim can be used to cover any external 90 degree profile. Cut to size with square ends or mitred ends. Check sizes are correct by laying in position, if good then remove trim. Run a small bead of exterior grade adhesive silicone down the centre of the backside of the trim but not too much that it squeezes out, then carefully position the trim. Then using a 2mm drill bit, drill 30mm from the ends and equally space the rest of the holes at approximately 600 centres for coloured screws. Check that the screws fix to the timber sub-frame, you may have to adjust hole locations across the width of the trim

Expansion & Contraction

As all products expand and contract, we recommend installing the boards with a 4-5mm gap at the ends of each board to allow for expansion. We also recommend a 12mm gap around the perimeter where the boards meet an upstand or wall.

When laying in warm summer conditions it is advisable to lay with a smaller gap as the boards will only get cooler and shrink.

When laying in cold winter conditions it is advisable to install with a larger gap as the boards will only get warmer and expand.

Castle Composites hold no responsibility for installations that are not carried out to instructions provided.